

# Hydraulic systems and components

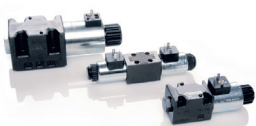
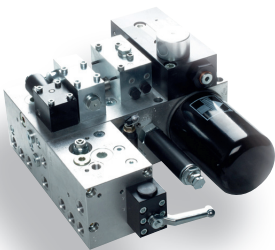

-  Quality
-  Security
-  Transparency

**AIR**  **tec**<sup>®</sup>  
vogel

# Hydraulic control blocks and hydraulic components of highest quality

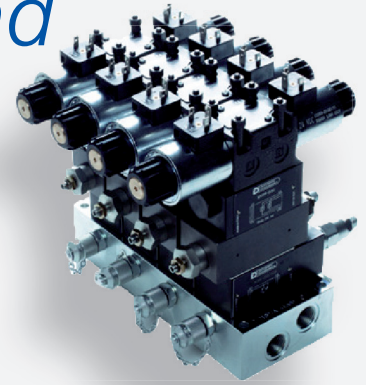

We are a modern company that has steadily and successfully developed in the developing and manufacturing of pneumatic motors and planetary gears, through customer-oriented and flexible thinking since its foundation in 2004.

Our special strength as a company lies in the comprehensive know-how and the experience of our employees in the field of fluid

technology, mechanics, metal working and assembly technology.

Since 2010 we have extended our product range as a system manufacturer for clamping hydraulic systems. You need absolutely reliable clamping hydraulic and control block solutions for your manufacturing and your hydraulic components.

## We already are fluid partner for the following market segments:

- *Fixture and mould construction*
- *Machine tool building*
- *Automobile manufacturer and supply industry*
- *Special engineering*
- *Clamping hydraulics*

Even though we collaborate with well-known manufacturers, we are free to deve-

lop the most suitable solution for your individual application.

The special benefit for our customers is the service from a single source – from the first idea to the ready-to-mount product, you will be provided a comprehensive range of services from us.

Our many years of experience in the field of fluid technology will be available to you at all times.

# Block-, round- or flange cylinders

- in steel and aluminium design  
for various design types

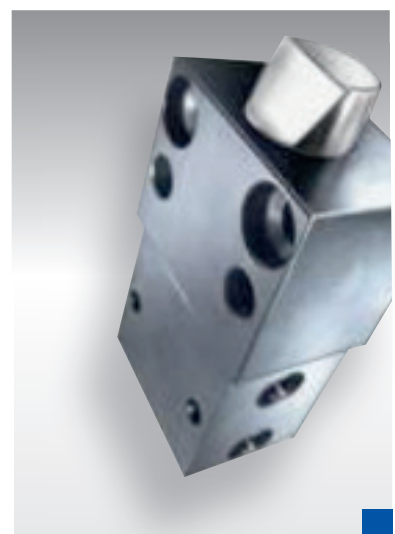

Air-tec-Vogel® offers an extensive and high-quality hydraulic cylinder programme especially for the mould and fixture construction:

- Piston diameter from  $\varnothing 16$  to  $\varnothing 200$
- Various fastening options
- Hardened and polished piston rods
- Various switch types for end-position sensing
- Maximum operating pressure 500 bar

# Complete solutions

## ■ Compact and clamping units



Our control blocks that are already equipped with valves offer you the possibility to cut costs and reduce risk. The installation and



function test of the complete unit guarantee a consistent quality level.

# Special solutions

## ■ according to your demand profile with proven standard components

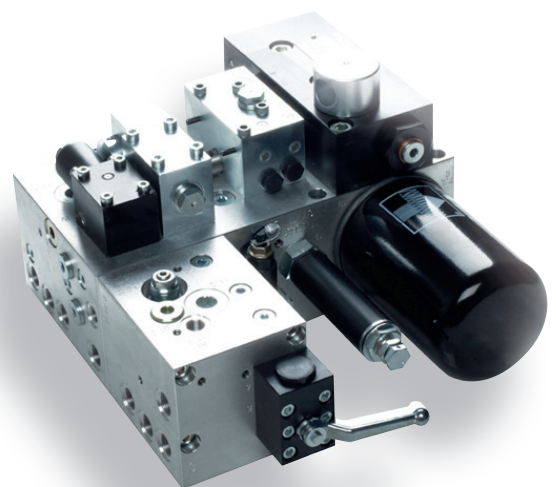

# Directional control valves

■ for block design

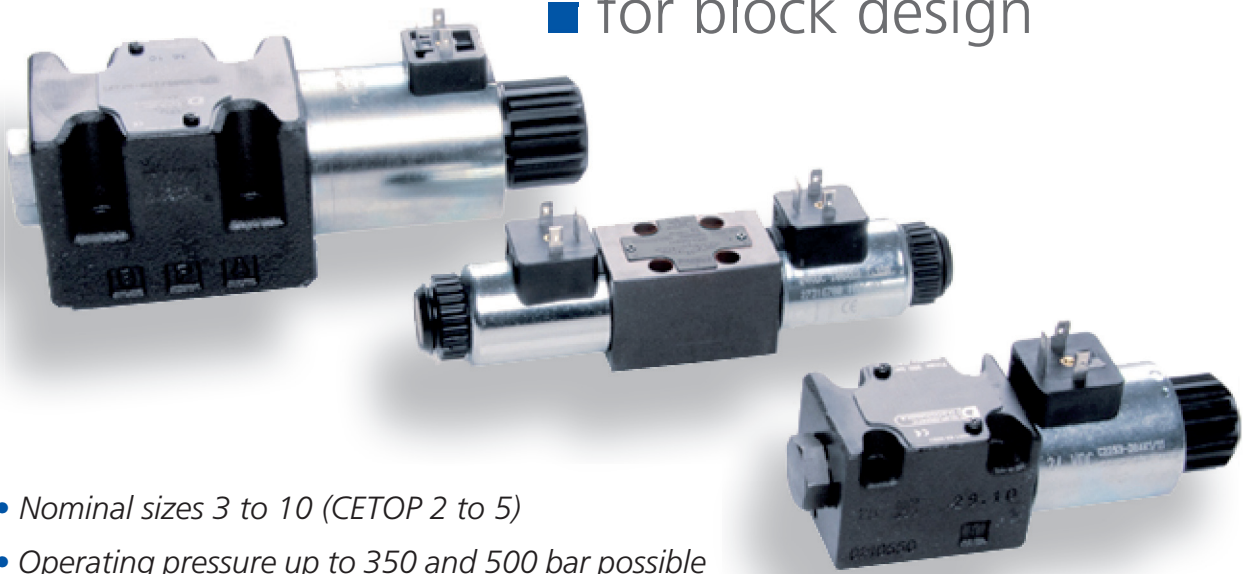

- Nominal sizes 3 to 10 (CETOP 2 to 5)
- Operating pressure up to 350 and 500 bar possible
- Flow rate max. 140 l/min

# Screw-in valves

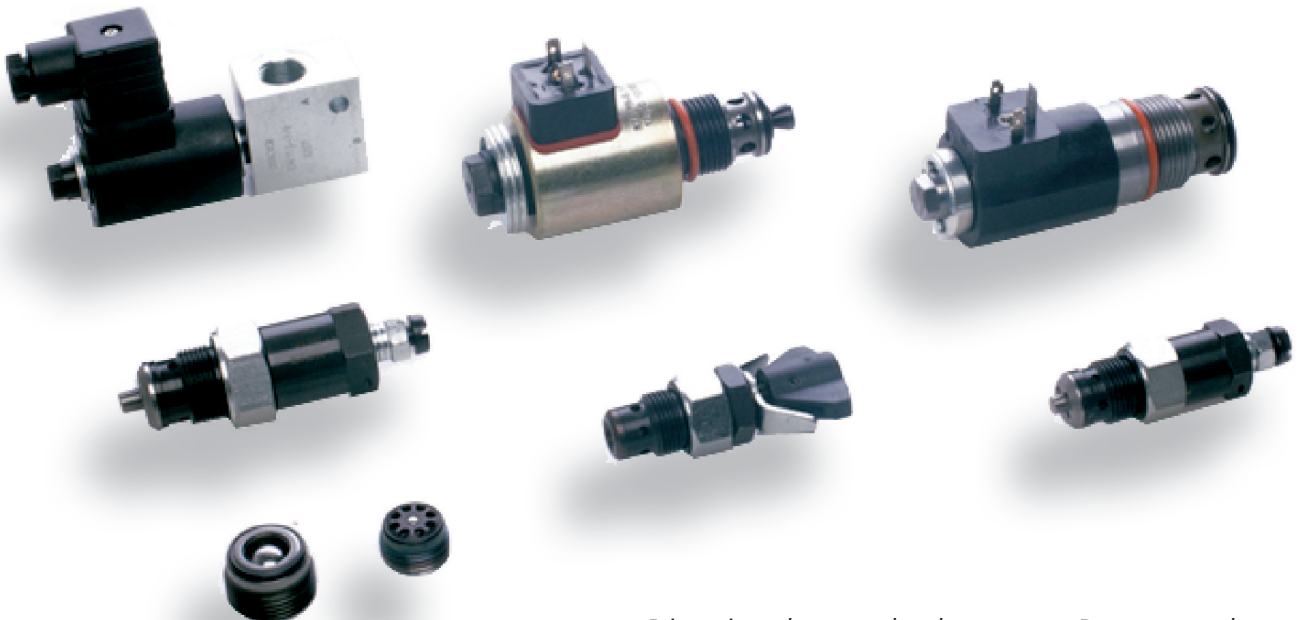

- Directional control valves
- Pressure valves
- Flow valves
- Shut off valves

Up to 60 l/min and 500 (700) bar

# Clamping hydraulic solutions

Air-tec-vogel® developed a supplies- and valve programme especially adapted to the tool and fixture construction.

## Advantages:

- Partially compatible with products of German manufacturers
- Short lead times
- Low storage costs for the customer
- Made in Germany



## Interlinking blocks

- for the clamping technology, adjustable through modular system



# Swing or lever clamps

■ available from 70 to 500 bar

Air-tec-vogel® developed hydraulic build-in swing clamps especially for the fixture construction. This concept with only a few components underlies an extremely low wear compared to the usual swing clamp cylinders. The piston has no leading function at the cylindrical shell. The actual leading function is taken over by the swivelling bushing and the pilot pin on the piston rod, as well as by the cylinder head. Thereby higher clamping forces, as for instance

with longer tensioning arms, can be submitted. Also in case of service, the low number of components can be replaced in a short time.

## Advantages:

- *Through smaller dimensions of the clamping elements the number of work pieces on the work piece carrier is increased*
- *Higher flexibility at lower acquisition costs*
- *High clamping forces of 5.8 to 22.5 kN at low hydraulic pressure of 50bar to 200bar*
- *Pneumatic clamping position monitoring*
- *Dirt wipers for better protection against hot metal cuttings*
- *Clamping elements as modular system*
- *Indexing for clamping arm*
- *With clamping position adjustment*

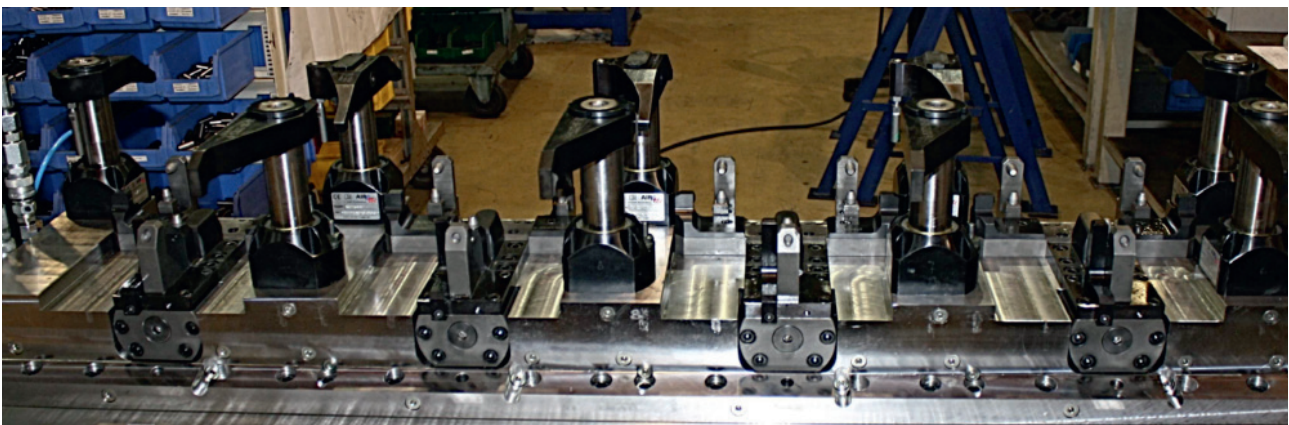
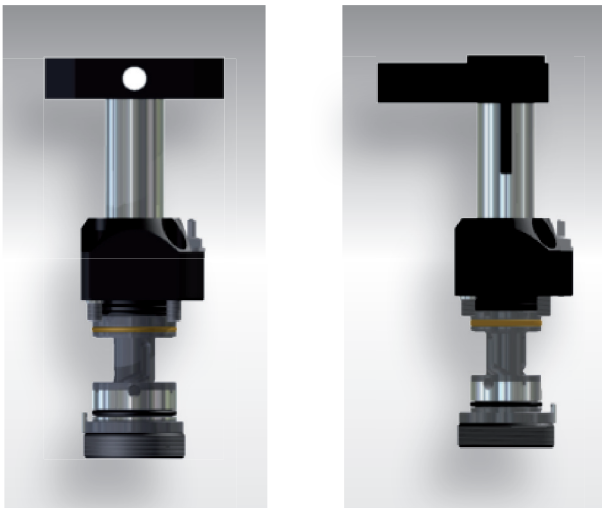

*Please contact us  
for our other catalogues!*

*Assembly and workplace systems*



*Drill feed units*



*Electrical screwdrivers*

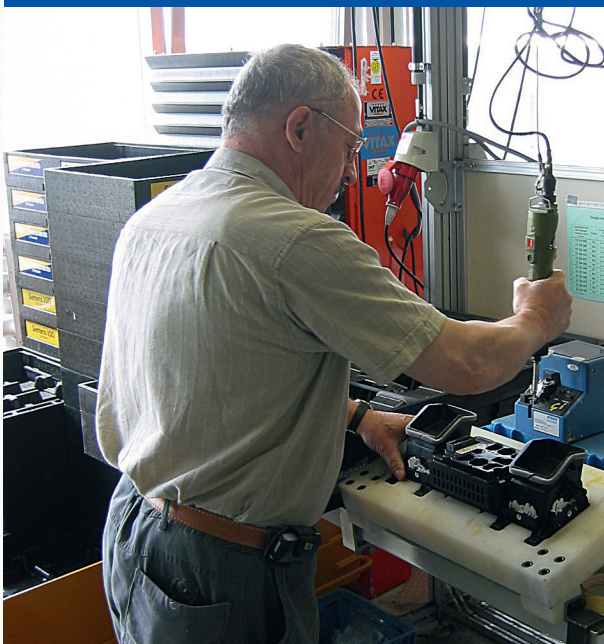

*Product catalogue*



**AIRtec-Vogel GmbH**

Brunnenstraße 48, D-35460 Staufenberg

Phone: +49 (0) 64 06/ 7758483

Fax: +49 (0) 64 06/ 7758481

[www.air-tec-vogel.de](http://www.air-tec-vogel.de), [info@air-tec-vogel.de](mailto:info@air-tec-vogel.de)

Quality is nothing without intelligent control.

Your AIRtec-vogel®-partner